

M5 E160-60 LOT BOX (FOR REFERENCE, NOT INCLUDED)

Ø 1.0" 304 SS RND TUBE HANDLE, 2X

METRO DONUT BUMPER MOUNTED TO HANDLE, 4X

.50" X 1.5" X 16GA 304 SS SHELF FRAME, 3X

304 SS ROD LOT BOX SUPPORTS

1.5" SQ 16GA 304 SS BASE FRAME

Ø 6.0" SWIVEL SHOCK ABSORBING CASTER W/BRAKE, 4X

12GA 304 SS UPRIGHTS W/VIBRATION ISOLATORS MOUNTED UNDER EACH SHELF

**CAPACITY: 18 M5 E160-60 LOT BOXES**

**ELECTROPOLISH FINISH**

NOTE: ALL DIMENSIONS ARE ± 1/8" AT FINAL INSPECTION.

**PROPRIETARY AND CONFIDENTIAL**

THE INFORMATION CONTAINED IN THIS DRAWING IS THE SOLE PROPERTY OF PRO-FAB, INC. ANY REPRODUCTION IN PART OR AS A WHOLE WITHOUT THE WRITTEN PERMISSION OF PRO-FAB, INC. IS PROHIBITED.

DIMENSIONS ARE IN INCHES UNLESS OTHERWISE SPECIFIED  
 .X = ± .060 ANGLES = ± .5  
 .XX = ± .030 CUTS = ± .030  
 .XXX = ± .010 HOLE DIA = ± .005  
 .XXXX = ± .005  
 WELDMENTS = .030

DRAWN  
ABL

SALES  
SS



VOICE (505) 869-2222  
 FAX (505) 869-3333  
 www.pro-fab.com

1040 BOSQUE FARMS BLVD-BOSQUE FARMS, NM 87068

TITLE:  
 E160-60 ANTI-VIBE CART  
 150 mm LOT BOX

DWG. NO.  
 02209GPF

SIZE **A** DATE: 2/20/2025 SCALE: NTS WEIGHT: LBS SHEET 1 OF 2

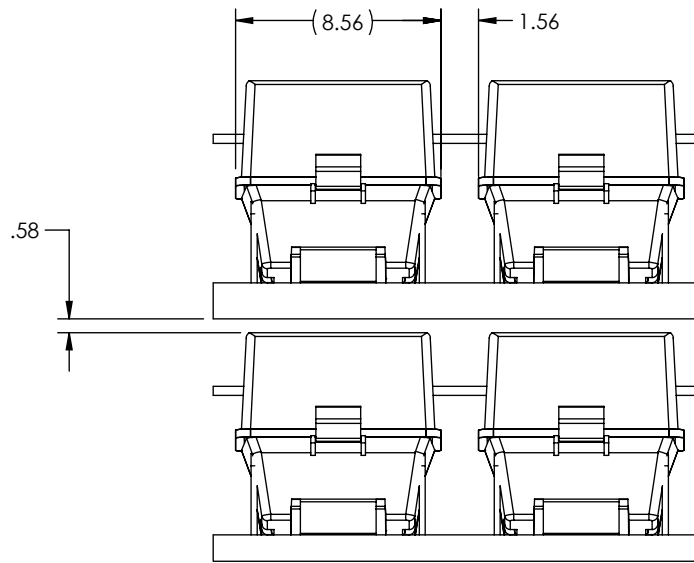
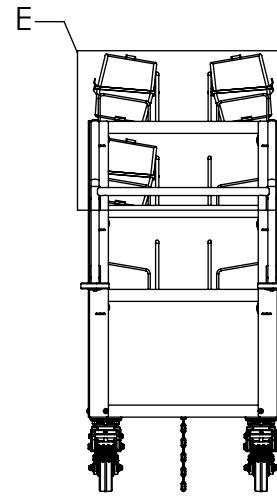
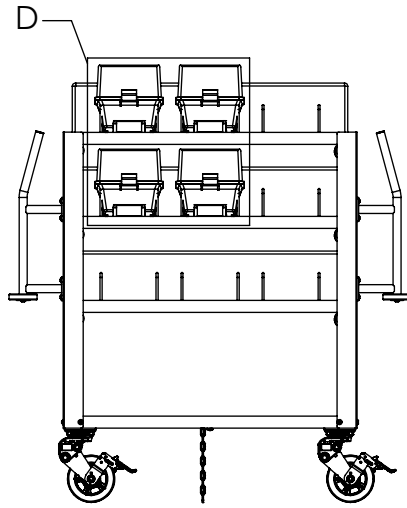

**DETAIL D**  
**SCALE 1 : 8**

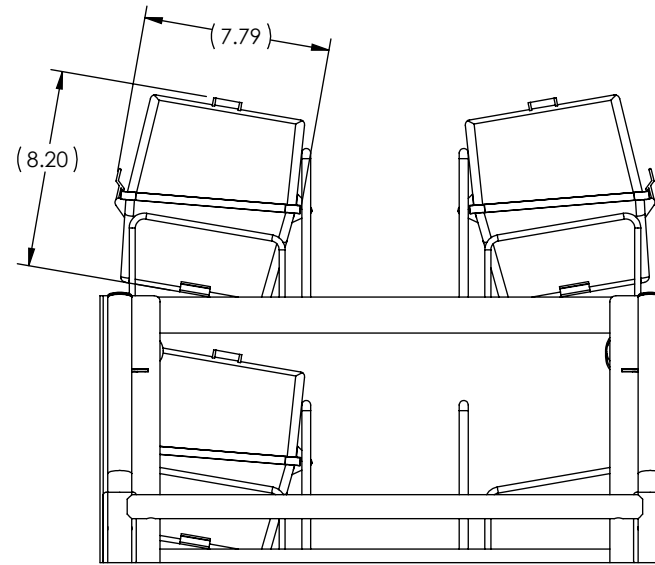

**DETAIL E**  
**SCALE 1 : 8**

**PROPRIETARY AND CONFIDENTIAL**  
THE INFORMATION CONTAINED IN THIS DRAWING IS THE SOLE PROPERTY OF PRO-FAB, INC. ANY REPRODUCTION IN PART OR AS A WHOLE WITHOUT THE WRITTEN PERMISSION OF PRO-FAB, INC. IS PROHIBITED.

DIMENSIONS ARE IN INCHES UNLESS OTHERWISE SPECIFIED  
.X = ± .060 ANGLES = ± .5  
.XX = ± .030 CUTS = ± .030  
.XXX = ± .010 HOLE DIA = ± .005  
.XXXX = ± .005  
WELDMENTS = .030

DRAWN  
SALES  
RC



VOICE (505) 869-2222  
FAX (505) 869-3333  
www.pro-fab.com

1040 BOSQUE FARMS BLVD-BOSQUE FARMS, NM 87068

TITLE:  
E160-60 ANTI-VIBE CART  
150 mm LOT BOX

DWG. NO.  
02209GPF

SIZE **A** DATE: 2/20/2025 SCALE: NTS WEIGHT: LBS SHEET 2 OF 2