

- 304 SS CONSTRUCTION
- ELECTROPOLISH FINISH
- 14 LOT BOX CAPACITY

NOTE: ALL DIMENSIONS ARE ± 1/8" AT FINAL INSPECTION.

**PROPRIETARY AND CONFIDENTIAL**

THE INFORMATION CONTAINED IN THIS DRAWING IS THE SOLE PROPERTY OF PRO-FAB, INC. ANY REPRODUCTION IN PART OR AS A WHOLE WITHOUT THE WRITTEN PERMISSION OF PRO-FAB, INC. IS PROHIBITED.

DIMENSIONS ARE IN INCHES UNLESS OTHERWISE SPECIFIED  
 .X = ± .060 ANGLES = ± .5  
 .XX = ± .030 CUTS = ± .030  
 .XXX = ± .010 HOLE DIA = ± .005  
 .XXXX = ± .005  
 WELDMENTS = .030

DRAWN  
ABL

SALES  
SS



**PRO-FAB** INC.

VOICE (505) 869-2222  
 FAX (505) 869-3333  
 www.pro-fab.com

1040 BOSQUE FARMS BLVD-BOSQUE FARMS, NM 87068

TITLE:  
150 mm LOT BOX ANTI-VIBE CART  
W/ WORKSTATION

DWG. NO.

02209HPF

SIZE **A**

DATE: 2/21/2025

SCALE: NTS

WEIGHT: LBS

SHEET 1 OF 3

- UPPER WIP NEST MOUNTED ON VIBRATION ISOLATORS.
- LOWER TWO SHELVES MOUNTED ON VIBRATION ISOLATORS.
- UPPER WIP NEST ALLOWS FOR ONE LOT BOX TO BE OPEN AT A TIME.

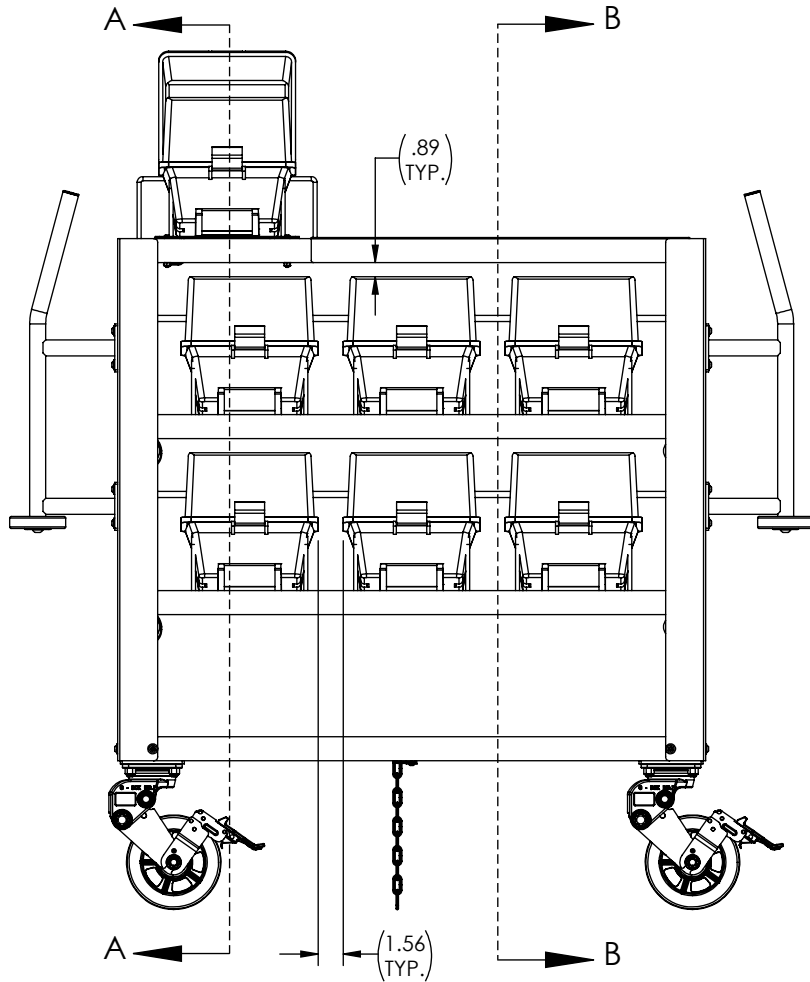

SHEET 3

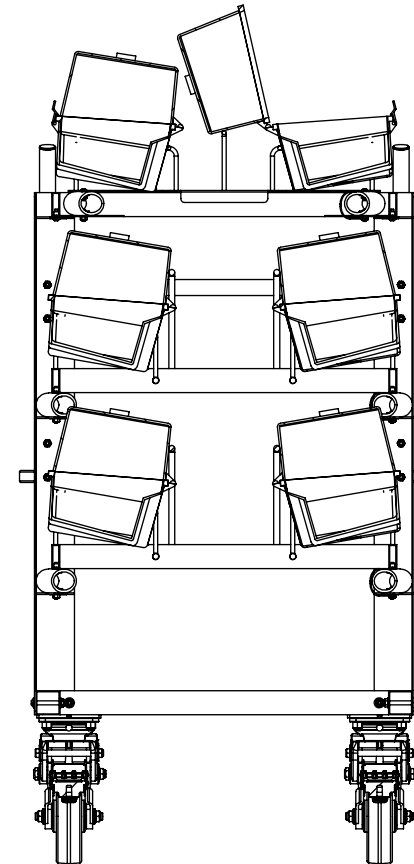

SECTION A-A  
SCALE 1 : 12

**PROPRIETARY AND CONFIDENTIAL**

THE INFORMATION CONTAINED IN THIS DRAWING IS THE SOLE PROPERTY OF PRO-FAB, INC. ANY REPRODUCTION IN PART OR AS A WHOLE WITHOUT THE WRITTEN PERMISSION OF PRO-FAB, INC. IS PROHIBITED.

DIMENSIONS ARE IN INCHES UNLESS OTHERWISE SPECIFIED  
 .X = ± .060 ANGLES = ± .5  
 .XX = ± .030 CUTS = ± .030  
 .XXX = ± .010 HOLE DIA = ± .005  
 .XXXX = ± .005  
 WELDMENTS = .030

DRAWN  
ABL

SALES  
SS



VOICE (505) 869-2222  
 FAX (505) 869-3333  
 www.pro-fab.com

1040 BOSQUE FARMS BLVD-BOSQUE FARMS, NM 87068

TITLE:  
150 mm LOT BOX ANTI-VIBE CART  
W/ WORKSTATION

DWG. NO.  
02209HPF

SIZE **A**    DATE: 2/21/2025    SCALE: NTS    WEIGHT: LBS    SHEET 2 OF 3

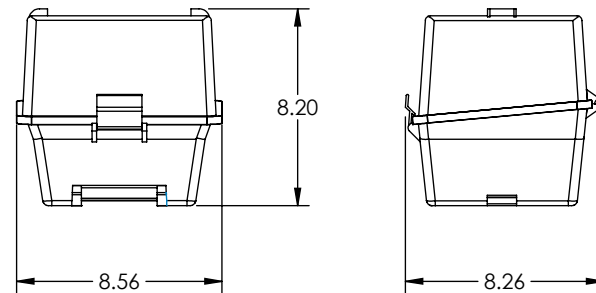
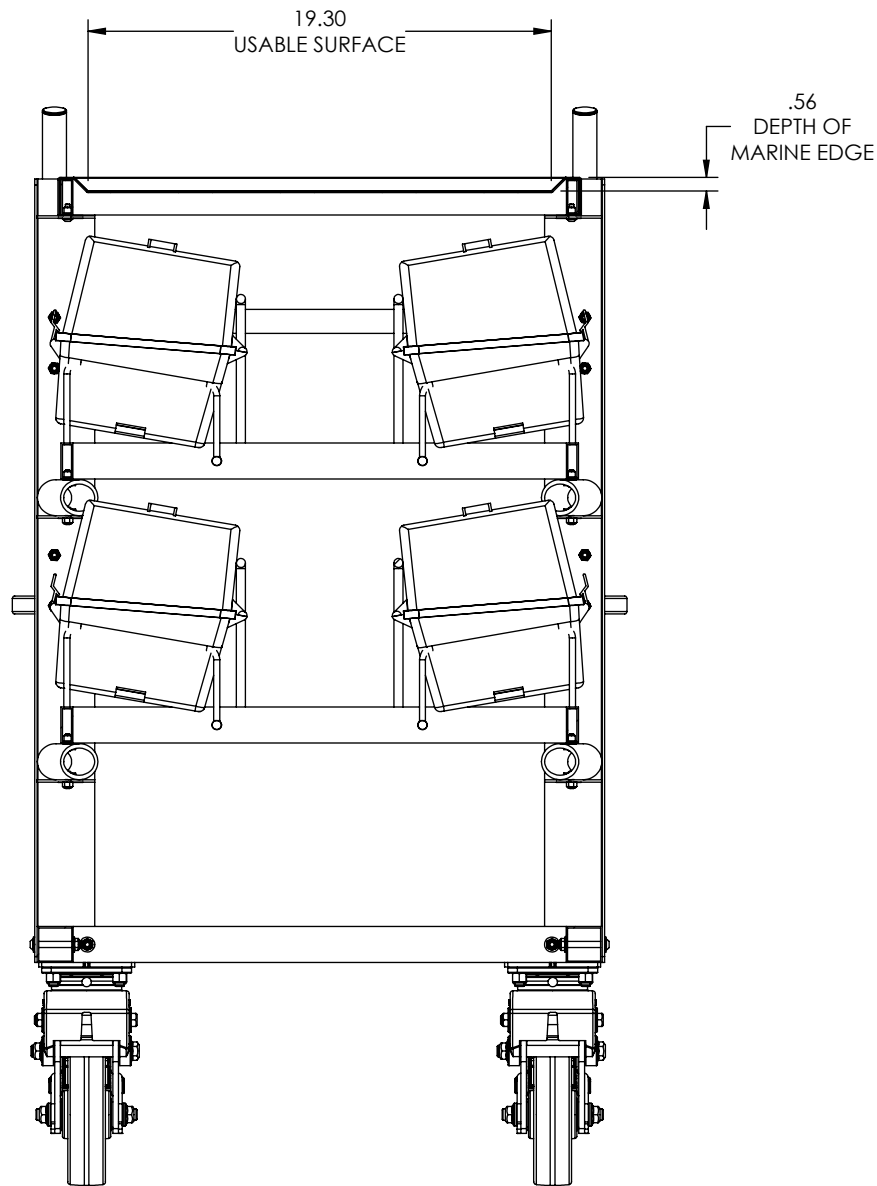

**E160-60 LOT BOX DIMENSIONS**

**SECTION B-B  
SCALE 1 : 8**

**PROPRIETARY AND CONFIDENTIAL**  
THE INFORMATION CONTAINED IN THIS DRAWING IS THE SOLE PROPERTY OF PRO-FAB, INC. ANY REPRODUCTION IN PART OR AS A WHOLE WITHOUT THE WRITTEN PERMISSION OF PRO-FAB, INC. IS PROHIBITED.

DIMENSIONS ARE IN INCHES UNLESS OTHERWISE SPECIFIED  
.X = ± .060 ANGLES = ± .5  
.XX = ± .030 CUTS = ± .030  
.XXX = ± .010 HOLE DIA = ± .005  
.XXXX = ± .005  
WELDMENTS = .030

DRAWN  
ABL  
SALES  
SS



**PRO-FAB** INC.

VOICE (505) 869-2222  
FAX (505) 869-3333  
www.pro-fab.com

1040 BOSQUE FARMS BLVD-BOSQUE FARMS, NM 87068

TITLE:  
150 mm LOT BOX ANTI-VIBE CART  
W/ WORKSTATION

DWG. NO.  
02209HPF

SIZE **A**

DATE: 2/21/2025

SCALE: NTS

WEIGHT: LBS

SHEET 3 OF 3