

VIBRATION ISOLATORS

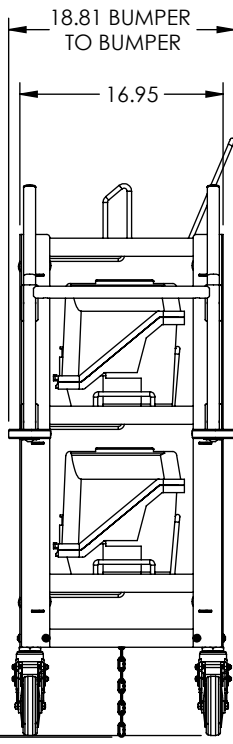
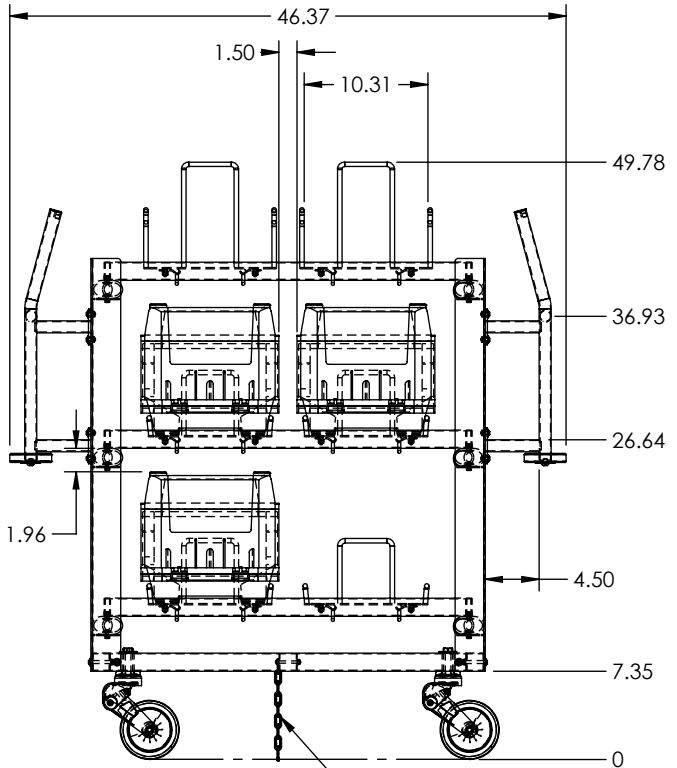

316SS GROUNDING DRAG CHAIN PASSIVATED

E210-80 CLEAR LOT BOX, FOR REFERENCE (NOT INCLUDED)

Ø 1" TUBE ERGO HANDLES ON BOTH ENDS OF THE CART

12GA ELECTROPOLISHED 304 STAINLESS STEEL VERTICAL SUPPORTS

METRO 9992DB RUBBER DONUT BUMPER, 4X

2 CLEAR LOT BOX SHELF, BOLT ON SURFACE

LOWER FRAME IS 1.5" SQ TUBE 16GA

ELECTROPOLISHED 304 STAINLESS STEEL FRAME AND SHELVES

4x GDS125 ANTIVIBE SWIVEL STUD MOUNT CASTER, NO BRAKE, 1.1875" TRAVEL

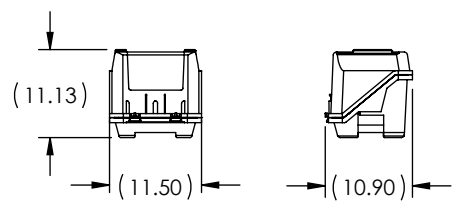

NOTE: ALL DIMENSIONS ARE ± 1/8" AT FINAL INSPECTION.

**PROPRIETARY AND CONFIDENTIAL**  
THE INFORMATION CONTAINED IN THIS DRAWING IS THE SOLE PROPERTY OF PRO-FAB, INC. ANY REPRODUCTION IN PART OR AS A WHOLE WITHOUT THE WRITTEN PERMISSION OF PRO-FAB, INC. IS PROHIBITED.

DIMENSIONS ARE IN INCHES UNLESS OTHERWISE SPECIFIED  
.X = ± .060 ANGLES = ± .5  
.XX = ± .030 CUTS = ± .030  
.XXX = ± .010 HOLE DIA = ± .005  
.XXXX = ± .005  
WELDMENTS = .030

DRAWN FR  
SALES  
SS

**PRO-FAB** INC. VOICE (505) 869-2222 FAX (505) 869-3333 www.pro-fab.com  
1040 BOSQUE FARMS BLVD-BOSQUE FARMS, NM 87068  
SIZE **A** DATE: 2/27/2025 SCALE: NTS WEIGHT: 105 LBS

TITLE:  
6 LOT ANTI-VIBRATION CART  
200 mm LOT BOX  
SHEET 1 OF 1

DWG. NO.  
02229WPF